

COMPLIANCE SUMMARY REPORT / PRODUCT SPECIFICATIONS

CARLRAY ANGLE BRACE
COMPLIES TO A.S. 1684-2010 RESIDENTIAL TIMBER-FRAMED CONSTRUCTION

Manufactured By

Carlray Pty Ltd
 448 The Boulevard
 Kirrawee N.S.W. 2232

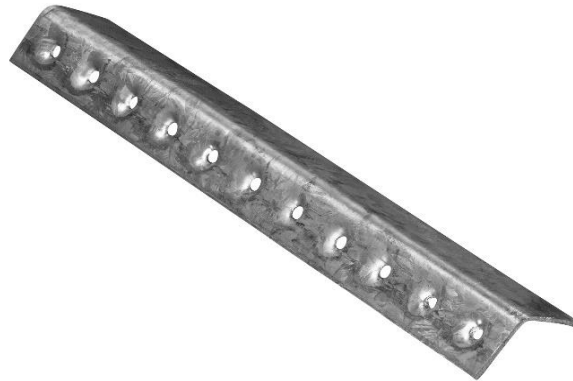

Product: Codes & Lengths

- 84819 - 3.0 Metres
- 84835 - 3.3 Metres
- 84851 - 3.6 Metres
- 84877 - 3.9 Metres
- 83893 - 4.2 Metres
- 84916 - 4.5 Metres
- 84932 - 4.8 Metres

APPLICATION

Angle Brace is designed to brace timber framed walls to maximum wall height 2.7m

SPECIFICATIONS

| Galvanized Coating | Material Size | Design Bracing Capacity |
|----------------------------|-----------------|-------------------------|
| Z275 | 20 x 18 x 1.2mm | (0.8kN/m) (1.5kN/m) |
| Compliance to AS 1684-2010 | | |

Table 8.18(a) Bracing Capacity 0.8 Kn/M

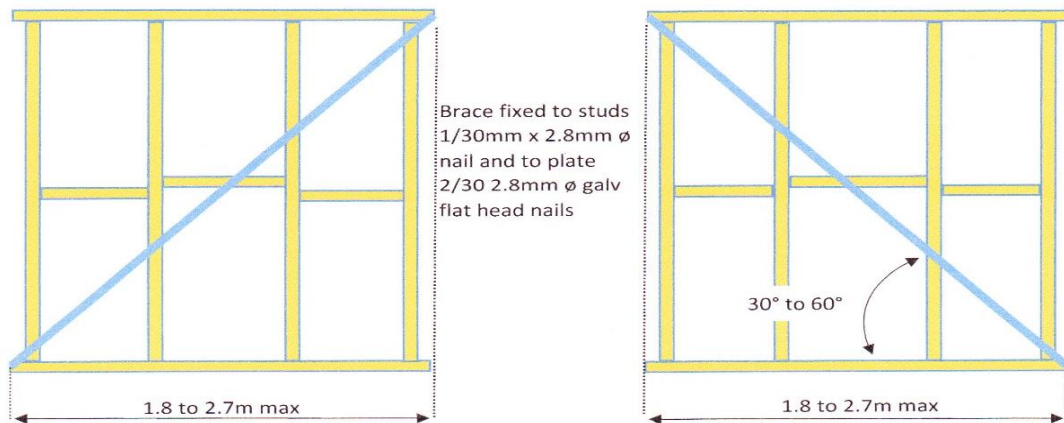

Table 8.18(c) Bracing Capacity 1.5kN/m

